

CIRCULAR PERMANENT MAGNETIC CHUCK



SAV 244.01

with fine parallel pole divisions $P=1.9$ mm

Application:

For holding small and thin up to medium sized components.

Features:

Powerful magnetic system with Neodymium magnets and a low magnetic field.

Holding force is continuously variable.

Supplied with flange on request (see SAV 248.90 till 248.94).

Nominal holding force: 100 N/cm² (A=100: 70 N/cm²)

Magnetic field height: 8 mm

Usable top plate life: 5 mm

Dimensions in mm										Weight in kg
A	B ₁	C	D	E	F	G	H	J		
100	50	77	60	85	4 x M8	4	10	20x14		3.0
130	50	103	90	115	4 x M8	4	10	20x14		5.0
150	50	117	110	132	4 x M8	4	10	24x5		7.0
160	57	116	125	142	4 x M8	4	16	24x5		9.0
200	57	154	150	180	4 x M8	4	16	200x5		15.0
250	57	192	200	232	4 x M8	4	16	250x5		20.0
300	62	227	250	285	4 x M8	4	16	300x5		31.0
350	62	293	300	334	4 x M8	5	22	350x5		43.8
400	67	324	300	350	6 x M10	5	22	400x5		62.7
450	67	372	350	400	6 x M10	5	22	450x5		79.4
500	67	422	400	450	6 x M10	5	22	500x5		98.1

Ordering example:

Circular Permanent Magnetic Chuck SAV 244.01 - 150

Ordering key SAV - No. - A

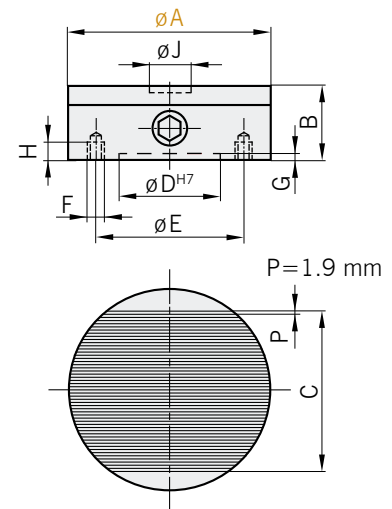
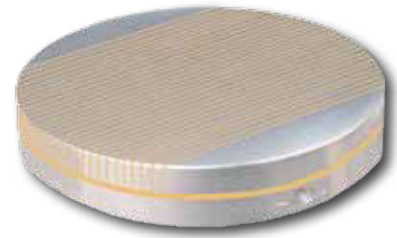

CIRCULAR PERMANENT MAGNETIC CHUCK



SAV 244.11

with close parallel pole divisions, powerful magnetic system $P=11$ and 15 mm

Application:

For holding small up to large components for grinding and milling operations.

Features:

Powerful magnetic system with Neodymium magnets and a low magnetic field.

All sizes come with a single actuating spindle. Holding force is continuously variable.

Possibility to machine a pilot hole "H".

Supplied with flange on request (see SAV 248.90 till 248.94).

Nominal holding force: 150 N/cm² (A=160: 120 N/cm²)

Magnetic field height: 10 mm

Usable top plate life: 6 mm

Dimensions in mm										
A	B ₁	C	D	E	F	G	H	J	P	Weight in kg
160	57	102	125	142	4 x M8	4	12	D15x6	8+3	8.0
200	57	146	150	180	4 x M8	4	12	D20x6	8+3	13.0
250	57	198	200	232	4 x M8	4	12	D25x20	12+3	20.0
300	62	228	250	285	4 x M8	4	12	D25x20	12+3	31.0
350	62	288	300	334	4 x M8	5	12	D25x20	12+3	43.0
400	67	318	300	350	6 x M10	5	20	D25x20	12+3	60.0
450	67	378	350	400	6 x M10	5	20	D25x20	12+3	76.0
500	67	408	400	450	6 x M10	5	20	D25x20	12+3	93.0

Ordering example::

Circular Permanent Magnetic Chuck SAV 244.11 - 250

Ordering key SAV - No. - A

